

E18MSP

SELETOR DE ESTOQUE DIRIGÍVEL



KEY SPECS

Platform Height
18-ft / 5.5-m

Turning Radius
Zero

Platform Capacity
400-lb / 181-kg

Stowed Drive Speed
2.5 mph / 4 km/h

KEY FEATURES

- Designed with the operator in mind, featuring familiar controls, Point and Go steering, ergonomic joystick and ease of entry/exit from platform.
- Increase productivity with longer running batteries and optional platforms, trays and accessories.
- Lightweight and compact footprint is ideal for sensitive flooring and accessing tight spaces with high transportability.
- Quick access to key, known scissor components and durable mast protection offers efficient serviceability while the multi-display indicator provides real-time fault code and maintenance information to maximize uptime.

ACCESSORIES & OPTIONS

- Anti-Vandalism Package
- ClearSky™
- Front and Side Bumpers
- CleanGuard™
- Crane Hook
- USB Charger & Phone Cradle

STANDARD SPECIFICATIONS

Performance	Indoor ONLY
Platform Height (Elevated)	18-ft / 5.5-m
Working Height	24-ft / 7.5-m
Platform Capacity	400-lb / 181-kg
Work Tray Capacity	100-lb / 45-kg
Number of Occupants	1
Lift / Lower Time ¹	23/23 seconds
Maximum Drive Height	Fully Elevated
Weight*	1,950-lb / 885-kg
Ground Bearing Pressure	TBD
Drive Speed (Elevated)	0.5 mph / .8 km/h
Drive Speed (Lowered)	2.5 mph / 4 km/h
Gradeability	30%
Turning Radius (Inside)	Zero
Turning Radius (Outside)	48-in / 1.2-m

Power Source

Battery	Four 6V - 220 AH (2X More Duty Cycles Over Competition)
Charger	27 amp
Drive	4 Brush Direct Electric Drive (Planetary Gear)

Lift & Steer Systems

Lift	Hydraulic
Steer	Point & Go

Tires

Front / Rear	8-in Casters / 10 x 3-in Non-Marking
--------------	--------------------------------------

Brakes

Electric	
----------	--

STANDARD FEATURES

- 27 amp Multi-Function Universal Charger
- DC Electric Drive
- 28 x 29.5-in Side Entry Work Tray Platform with Saloon Doors and Gate Alarm
- Dual Amber Beacon
- AC Receptacle in Platform
- Dynamic Braking
- Active Pothole Protection System
- Electric Brake Release
- All Motion Alarm
- Floor Mat
- Analyzer Port for Diagnostics
- Fork Lift Pockets
- Battery Condition Indicator
- Greaseless Kingpin Joints
- DC Electric Drive
- Manual Descent
- Mast Maintenance Prop
- Movable, Removable Platform Control with 6-ft Coiled Cable
- Multi-Display Indicator
- Proportional Controls
- Tilt Alarm and Light
- Telematics Ready
- Lifting and Tie Down Points

QUICK CHANGE PLATFORM OPTIONS

- Fold-Down Work Tray Platform
- Platform Entry Styles
- 28 x 29.5-in
- Side Entry Drop Bar
- Platform Capacity, 400-lb
- Aluminum Tray with Side Entry Saloon Doors
- Tray Capacity, 100-lb

E18MSP

SELETOR DE ESTOQUE DIRIGÍVEL



DIMENSIONS

All dimensions are approximate

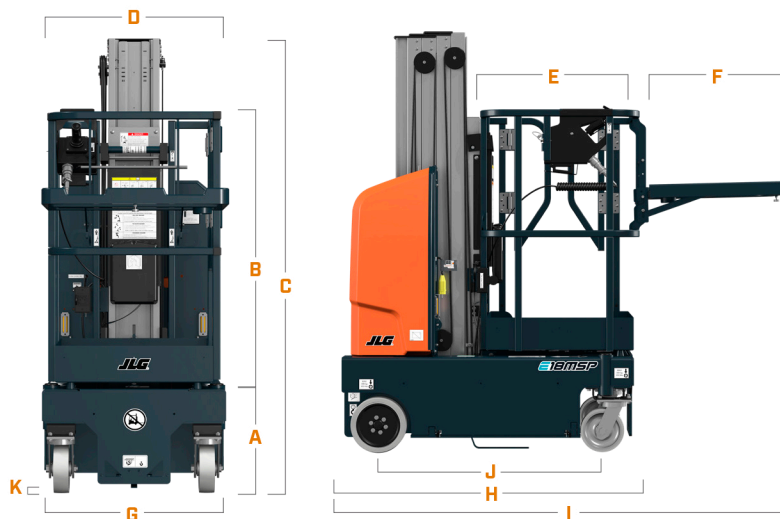

A. Platform Entry Height	18.5-in / 47-cm
B. Platform Rail Height	43.8-in / 1.11-m
C. Machine Height	78-in / 1.98-m
D. Platform Width	28-in / 71-cm
E. Platform Length	29.5-in / 75-cm
F. Platform Tray	25-in / 63-cm
G. Machine Width	30-in / 76-cm
H. Machine Length - Retracted Tray	57.6-in / 1.46-m
I. Machine Length - Extended Tray	81-in / 2.06-m
J. Wheelbase	41.4-in / 1.05-m
K. Ground Clearance	2.5-in / 6.35-cm

ACESSE NOSSO SITE



FORNECIMENTO DE PEÇAS ORIGINAIS JLG.
FORNECIMENTO DE MANUTENÇÃO ESPECIALIZADA.